

## TUFFY® T3

### Side Mounting Level Controls

Tuffy liquid level switches are float actuated devices designed for horizontal mounting in a tank or vessel through threaded or flanged pipe connections. The compact size allows for installation in small vessels, while its many features provide a variety of application uses. The single switch mechanism is available in SPDT or DPDT forms on units designed for adjustable, narrow or wide differential and interface service.

#### FEATURES

- \* Maximum Process temperature: +400 °C (750 °F).  
Minimum Process temperature: -55 °C (-65 °F).
- \* Maximum process Pressure: 150 bar abs (2160 psi).
- \* Specific gravities as low as 0.4.
- \* Wetted parts in 316/316L (1.4401/1.4404) or Hastelloy C (2.4819).
- \* Available as:
  - Flanged
  - Threaded
  - Flanged or sealed cage mounted.

#### MODELS

- \* Narrow differential switch (for alarm functions)
  - standard pressure (up to 50 bar abs (720 psi)
  - high pressure (up to 150 bar (2160 psi).
- \* Wide adjustable differential switch (for control functions)
- \* Interface switch (detection of interface level between liquids).
- \* External cages.
- \* Compact versions:
  - pneumatic narrow differential switch
  - electric narrow differential switch.

#### APPLICATIONS

- \* Sour service (NACE).
- \* High/low alarm.
- \* Single pump control.
- \* Day storage tanks.
- \* Corrosive processes.
- \* Process vessels.
- \* Boiler low water cut off.
- \* Interface level.
- \* Dirty process high level w/offset.
- \* Installations in hazardous area.

#### Compact and cost effective

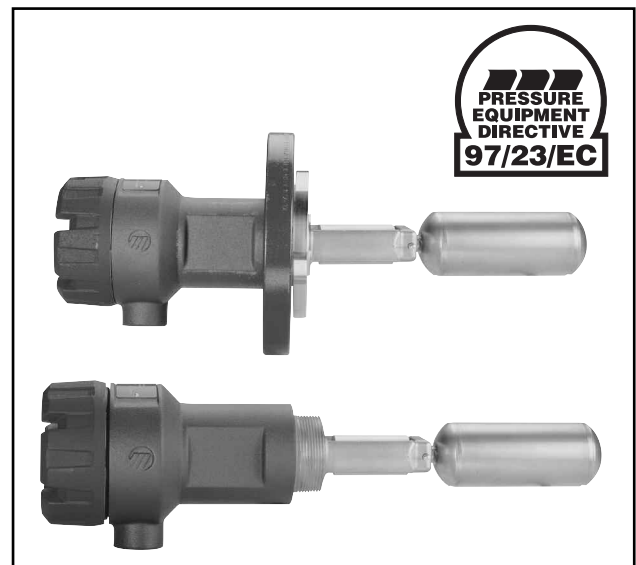

#### External cage mounted Tuffy

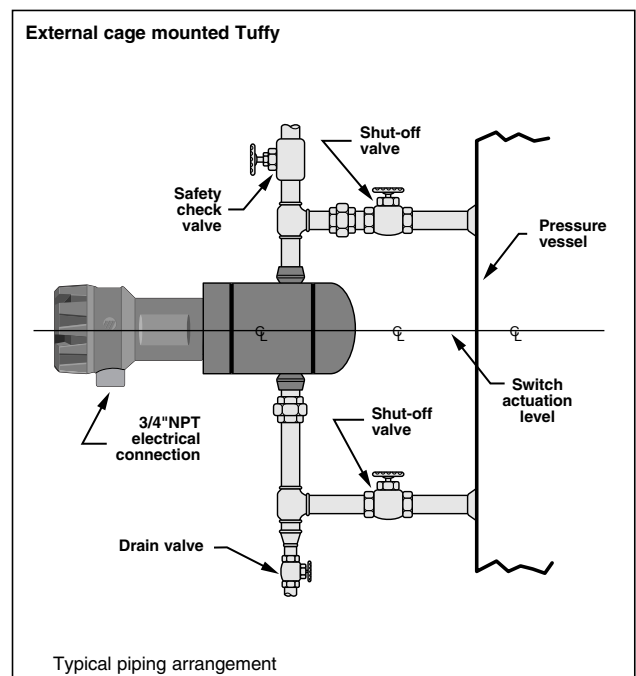

#### AGENCY APPROVALS

Agency	Approvals (only for T3-series)
ATEX (zone 0)	II 1/2G EEx d II C T6, explosion proof II 1G EEx ia II C T6, intrinsically safe
FM/CSA®	Explosion proof

① Consult factory for proper partnumbers

## SWITCH MECHANISMS

All TUFFY® are available with a selection of switch modules that vary in switch rating (Amp) and max process temperature allowance. The max temperature is dependent upon the housing material selected. Consult table below, before selecting the proper module in the order number structure on pages 3, 5, 7 or 9.

Code	Contacts and type	Electric switch rating				Process temperature range @ 40 °C (100 °F) ambient temp.	
		V AC		V DC		Cast Iron	Cast Aluminium
0	SPDT with silver contacts	10.0	10.0	6.0	0.6	-40 °C to +400 °C (-40 °F to +750 °F)	-40 °C to +345 °C (-40 °F to +650 °F)
1	DPDT with silver contacts	10.0	10.0	6.0	0.6	-40 °C to +400 °C (-40 °F to +750 °F)	-40 °C to +345 °C (-40 °F to +650 °F)
2	SPDT with gold plated contacts	0.1	-	0.1	-	-40 °C to +190 °C (-40 °F to +375 °F)	-40 °C to +160 °C (-40 °F to +325 °F)
3	DPDT with gold plated contacts	0.1	-	0.1	-	-40 °C to +190 °C (-40 °F to +375 °F)	-40 °C to +160 °C (-40 °F to +325 °F)
4	HS SPDT with silver contacts	1.0	1.0	3.0	0.5	-55 °C to +400 °C (-65 °F to +750 °F)	-55 °C to +345 °C (-65 °F to +650 °F)
6	HS SPDT with gold plated contacts	0.5	0.5	0.5	0.5	-55 °C to +400 °C (-65 °F to +750 °F)	-55 °C to +345 °C (-65 °F to +650 °F)

## HOUSINGS

All TUFFY® are available with an IP 65 weatherproof housing in anti corrosive coated cast iron or cast aluminium. The TUFFY® housings are built to meet explosion proof requirements according to ATEX, FM or CSA norms.

The wetted parts are available in 316/316L (1.4401/1.4404) or Hastelloy C (2.4819).

All dark-grey coloured parts of below drawing follow the materials as per housing selection, all light-grey coloured parts follow the materials as per float selection (wetted parts).

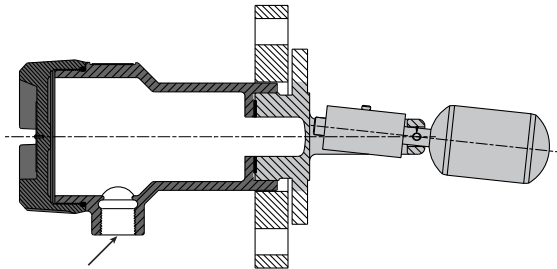

Cable entries: M20 x 1.5 or 3/4" NPT

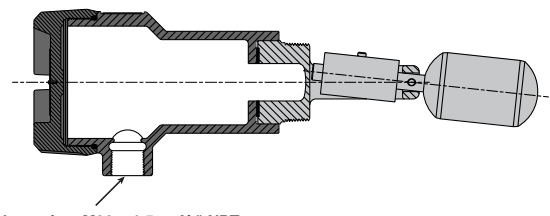

Cable entries: M20 x 1.5 or 3/4" NPT

## PHYSICAL SPECIFICATIONS

Description	Specification
Measured variable	Liquid level
Physical range	Narrow differential: 13 mm (0.5") Adjustable differential: up to 464 mm (18.26") Interface Service Differential: 44 mm (1.72") Interface: min S.G. difference between both liquids: 0,1
Process temperature	From -55 °C (-65 °F) up to +400 °C (750 °F) depending switch/housing selection
Process pressure	Standard models: up to 50 bar abs. (720 psi) High pressure models: up to 150 bar abs. (2160 psi)
Wetted parts	316/316L (1.4401/1.4404) or Hastelloy C (2.4819)
Flange materials	Carbon steel 316/316L (1.4401/1.4404) or Carbon steel with 316/316L (1.4401/1.4404) cladding Hastelloy C (2.4819) or Carbon steel with Hastelloy C (2.4819) cladding
Housing materials	Cast aluminium or cast iron

## ELECTRICAL SPECIFICATIONS

Description	Specification
Switch ratings	Up to 10 A @ 240 V AC Up to 6.0 A @ 24 V DC
Signal output	Single SPDT or single DPDT contacts
Switch types	Dry contact with silver or gold plated contacts Hermetically sealed for corrosive environment
Approvals	ATEX II 1/2G EEx d II C T6, explosion proof (Zone 0) ATEX II 1G EEx ia II C T6, intrinsically safe NEMA 4X/7/9, Class 1, Div 1, Groups B, C & D
Cable entries	3/4" NPT and M20 x 1,5

## PRINCIPLE OF OPERATION

The Tuffy achieves switching action through the use of a magnetic switch mechanism and a magnet attached to the float assembly. Separating the two magnets is a non-magnetic pressure barrier.

As the liquid level changes, the float, and therefore the float magnet, moves. The float and switch magnets repel each other causing movement of the switch mechanism, tripping the switch and making or breaking an electrical circuit.

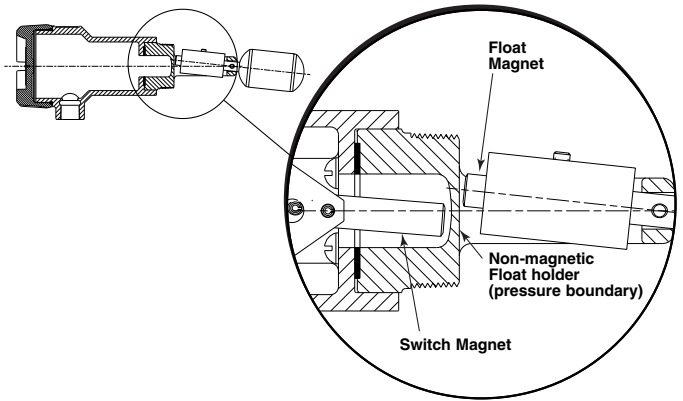

## SELECTION DATA

- Narrow Differential: Switch differential of approximately 13 mm (0.5") (44 mm (1.72") on interface unit), for actuation of an alarm or system shutdown.
- Wide Differential: Switch differential from approximately 23 mm (0.91") to 127 mm (5.01"), for valve or pump control.
- Interface Service: Switch to detect the interface between two liquids with SGs that differ by at least 0,1 kg/dm<sup>3</sup>.
- Single Liquid: Switch to detect the top of layer of a single liquid with no other liquid above it.
- Adjustable Differential: Wide switch differential from approximately 35 (1.36") to 464 (18.26"), which may be adjusted in the field by repositioning pins on the pivot plate.

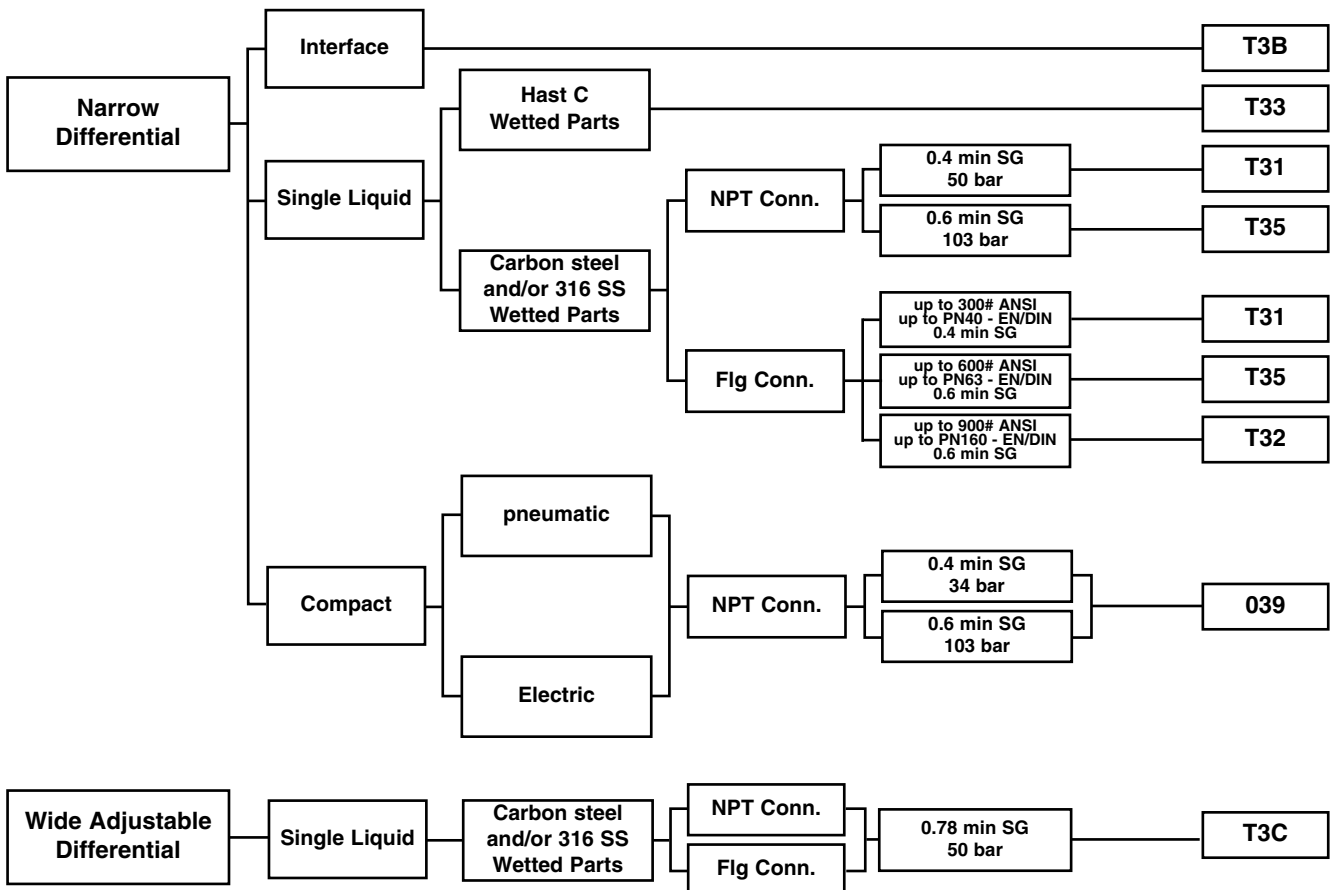

## EXPEDITE SHIP PLAN (ESP)

Several Tuffy devices are available for quick shipment, within max. 3 weeks after factory receipt of purchase order, through the Expedite Ship Plan (ESP).

Models covered by ESP service are conveniently colour coded in the selection data charts.

To take advantage of ESP, simply match the colour coded model number codes (standard dimensions apply).

ESP service may not apply to orders of ten units or more. Contact your local representative for lead times on larger volume orders, as well as other products and options.

# T31 AND T35: THREADED NARROW DIFFERENTIAL

DIMENSIONS in mm (inches)

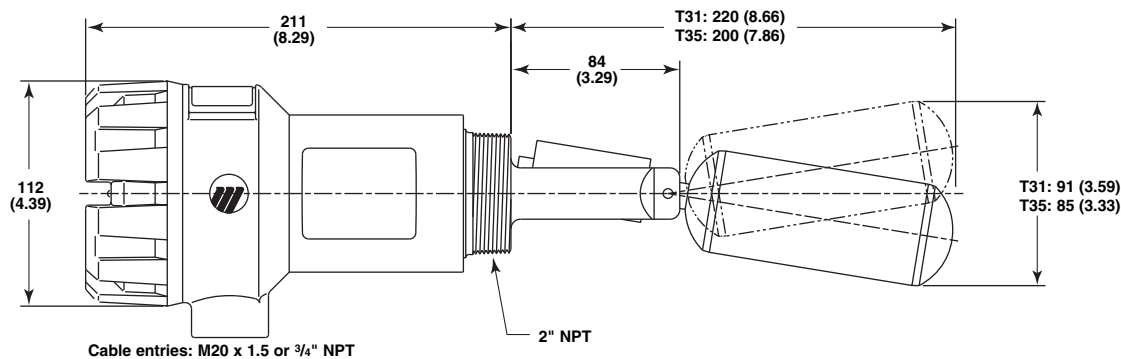

## ORDER CODE

Process connection: 2" NPT

Max temperature: switch selection dependant – see table on page 2

Max pressure: 50 bar abs. (720 psi) / 103 bar abs. (1500 psi)

Level Differential: 13 mm (0,5")

T 3 1 - 0 0 2 N	Threaded Tuffy with 316/316L (1.4401/1.4404) float - min. S.G. 0,4 / max 50 bar abs. ( 720 psi)
T 3 5 - 0 0 2 N	Threaded Tuffy with 316/316L (1.4401/1.4404) float - min. S.G. 0,6 / max 103 bar abs. (1500 psi)

### DESIGN CODE (All wetted parts in 316/316L (1.4401/1.4404))

B	Standard design
F	ANSI/ASME B31.3 design
K	NACE design
P	NACE & ANSI/ASME B31.3 design

### SWITCH TYPE (see table on page 2 for full details)

0	SPDT with silver contacts
1	DPDT with silver contacts
2	SPDT with gold plated contacts
3	DPDT with gold plated contacts
4	Hermetically sealed, SPDT with silver contacts
6	Hermetically sealed, SPDT with gold plated contacts

### HOUSING MATERIALS AND CABLE ENTRY

Consult factory for proper partnumbers for FM/CSA approved units

1	Cast aluminium, single 3/4" NPT cable entry, ATEX II 1/2G EEx d II C T6
2	Cast iron, single 3/4" NPT cable entry, ATEX II 1/2G EEx d II C T6
3	Cast aluminium, single M20 x 1,5 cable entry, ATEX II 1/2G EEx d II C T6
4	Cast iron, single M20 x 1,5 cable entry, ATEX II 1/2G EEx d II C T6
M	Cast aluminium, single 3/4" NPT cable entry, ATEX II 1G EEx ia II C T6
N	Cast iron, single 3/4" NPT cable entry, ATEX II 1G EEx ia II C T6
P	Cast aluminium, single M20 x 1,5 cable entry, ATEX II 1G EEx ia II C T6
R	Cast iron, single M20 x 1,5 cable entry, ATEX II 1G EEx ia II C T6

T 3 0 0 2 N

complete order code for threaded TUFFY®

# T31, T33 AND T35: FLANGED NARROW DIFFERENTIAL

DIMENSIONS in mm (inches)

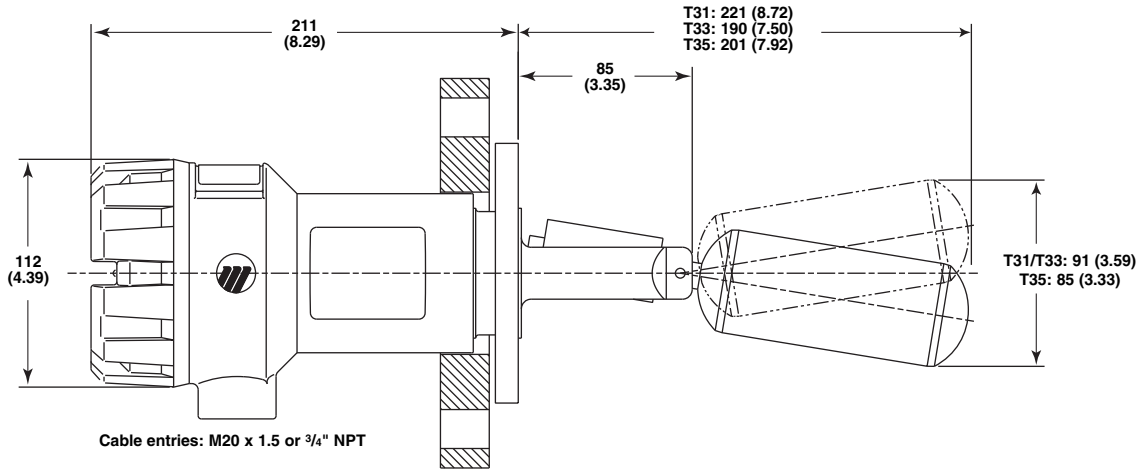

## ORDER CODE

Process connection: up to 600 lbs ANSI / PN 63 flanges

Max temperature: switch selection dependant – see table on page 2

Max pressure: 50 bar abs. (720 psi) / 103 bar abs (1500 psi), or limited to flange rating.

Level Differential: 13 mm (0.5")

T 3 1 - 0 0	Flanged Tuffly with 316/316L (1.4401/1.4404) float - min. S.G. 0,4 / max 50 bar abs. (720 psi)
T 3 3 - 0 0	Flanged Tuffly with Hastelloy C (2.4819) float - min. S.G. 0,65 / max 50 bar abs. (720 psi)
T 3 5 - 0 0	Flanged Tuffly with 316/316L (1.4401/1.4404) float - min. S.G. 0,6 / max 103 bar abs. (1500 psi)

### PROCESS CONNECTION – ANSI Flanges

3 A	3"	150 lbs RF ANSI Flange
3 B	3"	300 lbs RF ANSI Flange
3 C	3"	600 lbs RF ANSI Flange
4 A	4"	150 lbs RF ANSI Flange
4 B	4"	300 lbs RF ANSI Flange
4 C	4"	600 lbs RF ANSI Flange
6 B	6"	300 lbs RF ANSI Flange

### PROCESS CONNECTION – EN/DIN Flanges

A 1	DN 80, PN 16	EN 1092-1 Type B1
A 2	DN 80, PN 25/40	EN 1092-1 Type B1
A 3	DN 80, PN 63	EN 1092-1 Type B2
B 1	DN 100, PN 16	EN 1092-1 Type B1
B 2	DN 100, PN 25/40	EN 1092-1 Type B1
B 3	DN 100, PN 63	EN 1092-1 Type B2
D 2	DN 150, PN 25/40	EN 1092-1 Type B1

### DESIGN CODE AND FLANGE MATERIAL

Standard	Design codes			Flange material
	ANSI/ASME B31.3	NACE	ANSI/ASME B31.3 & NACE	
1	2	–	–	Carbon steel
A	E	J	N	Carbon steel w. 316/316L cladding
B	F	K	P	316/316L stainless steel
C <sup>Ⓞ</sup>	G <sup>Ⓞ</sup>	L <sup>Ⓞ</sup>	R <sup>Ⓞ</sup>	Carbon steel w. Hastelloy C cladding
D <sup>Ⓞ</sup>	H <sup>Ⓞ</sup>	M <sup>Ⓞ</sup>	T <sup>Ⓞ</sup>	Hastelloy C (2.4819)

<sup>Ⓞ</sup> Only valid for mod. T33

### SWITCH TYPE (see table on page 2 for full details)

0	SPDT with silver contacts
1	DPDT with silver contacts
2	SPDT with gold plated contacts
3	DPDT with gold plated contacts
4	Hermetically sealed, SPDT with silver contacts
6	Hermetically sealed, SPDT with gold plated contacts

### HOUSING MATERIALS AND CABLE ENTRY

Consult factory for proper partnumbers for FM/CSA approved units

1	Cast aluminium, single 3/4" NPT cable entry,	ATEX II 1/2G EEx d II C T6
2	Cast iron, single 3/4" NPT cable entry,	ATEX II 1/2G EEx d II C T6
3	Cast aluminium, single M20 x 1,5 cable entry,	ATEX II 1/2G EEx d II C T6
4	Cast iron, single M20 x 1,5 cable entry,	ATEX II 1/2G EEx d II C T6
M	Cast aluminium, single 3/4" NPT cable entry,	ATEX II 1G EEx ia II C T6
N	Cast iron, single 3/4" NPT cable entry,	ATEX II 1G EEx ia II C T6
P	Cast aluminium, single M20 x 1,5 cable entry,	ATEX II 1G EEx ia II C T6
R	Cast iron, single M20 x 1,5 cable entry,	ATEX II 1G EEx ia II C T6

T 3 0 0

complete order code for flanged TUFFY®

# T32: FLANGED HIGH PRESSURE NARROW DIFFERENTIAL

DIMENSIONS in mm (inches)

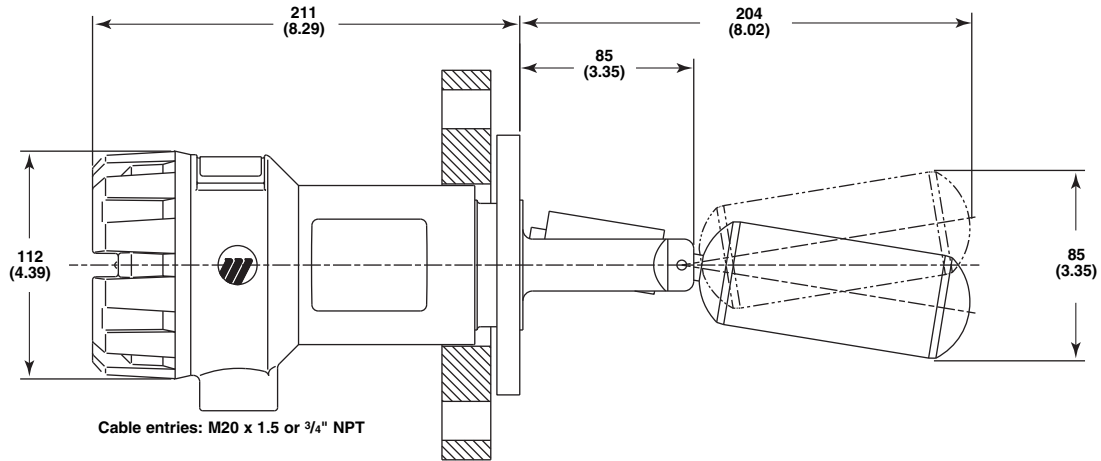

## ORDER CODE

Process connection: up to 900 lbs ANSI / PN 160 flanges  
 Max temperature: switch selection dependant – see table on page 2  
 Max pressure: 150 bar abs. (2160 psi)  
 Level differential: 13 mm (0,5")

T	3	2	-	0	0	Flanged Tuffy with 316/316L (1.4401/1.4404) float - min. S.G. 0,6 / max 150 bar abs. (2160 psi)
---	---	---	---	---	---	---

### PROCESS CONNECTION – ANSI Flanges

3	D	3"	900 lbs RF ANSI Flange
4	D	4"	900 lbs RF ANSI Flange

### PROCESS CONNECTION – EN/DIN Flanges

A	4	DN 80, PN 100	EN 1092-1 Type B2
A	5	DN 80, PN 160	DIN 2527 Form E flange
B	4	DN 100, PN 100	EN 1092-1 Type B2
B	5	DN 100, PN 160	DIN 2527 Form E flange

### DESIGN CODE AND FLANGE MATERIAL

Design codes				Flange material
Standard	ANSI/ASM B31.3	NACE	ANSI/ASM B31.3 & NACE	
1	2	-	-	Carbon steel
A	E	J	N	Carbon steel w. 316/316L cladding
B	F	K	P	316/316L stainless steel

### SWITCH TYPE (see table on page 2 for full details)

0	SPDT with silver contacts
1	DPDT with silver contacts
2	SPDT with gold plated contacts
3	DPDT with gold plated contacts
4	Hermetically sealed, SPDT with silver contacts
6	Hermetically sealed, SPDT with gold plated contacts

### HOUSING MATERIALS AND CABLE ENTRY

Consult factory for proper partnumbers for FM/CSA approved units

1	Cast aluminium, single 3/4" NPT cable entry,	ATEX II 1/2G EEx d II C T6
2	Cast iron, single 3/4" NPT cable entry,	ATEX II 1/2G EEx d II C T6
3	Cast aluminium, single M20 x 1,5 cable entry,	ATEX II 1/2G EEx d II C T6
4	Cast iron, single M20 x 1,5 cable entry,	ATEX II 1/2G EEx d II C T6
M	Cast aluminium, single 3/4" NPT cable entry,	ATEX II 1G EEx ia II C T6
N	Cast iron, single 3/4" NPT cable entry,	ATEX II 1G EEx ia II C T6
P	Cast aluminium, single M20 x 1,5 cable entry,	ATEX II 1G EEx ia II C T6
R	Cast iron, single M20 x 1,5 cable entry,	ATEX II 1G EEx ia II C T6

T	3	2	-	0	0				
---	---	---	---	---	---	--	--	--	--

complete order code for flanged high pressure TUFFY®

# T3C: ADJUSTABLE WIDE DIFFERENTIAL

DIMENSIONS in mm (inches)

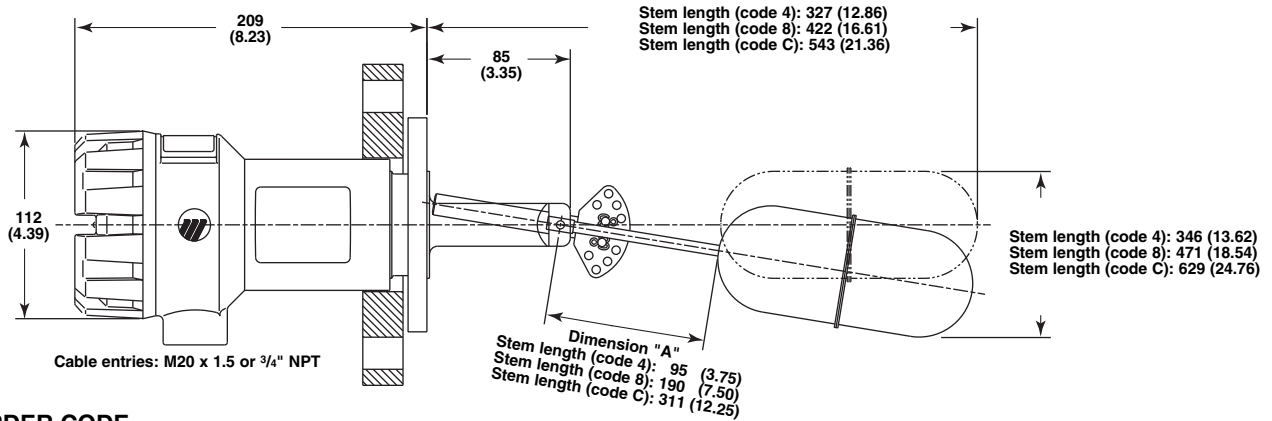

## ORDER CODE

Process connection: up to 300 lbs ANSI / PN 40 flanges  
Max temperature: switch selection dependant – see table on page 2  
Max pressure: 50 bar abs. (720 psi)  
Level Differential: adjustable from 35 mm (1.36") to 464 mm (18.26")

T	3	C	Adjustable diff. Tuffy with 316/316L (1.4401/1.4404) float - min. S.G. 0,78 / max 50 bar abs. (720 psi)
---	---	---	---

### STEM EXTENSION LENGTH - DIMENSION "A"

4	95 mm (3.75") stem extension
8	190 mm (7.50") stem extension
C	311 mm (12.25") stem extension

### PROCESS CONNECTION – ANSI Flanges

3	A	3"	150 lbs RF ANSI Flange
3	B	3"	300 lbs RF ANSI Flange
4	A	4"	150 lbs RF ANSI Flange
4	B	4"	300 lbs RF ANSI Flange
5	A	5"	150 lbs RF ANSI Flange
5	B	5"	300 lbs RF ANSI Flange
6	A	6"	150 lbs RF ANSI Flange
6	B	6"	300 lbs RF ANSI Flange

### PROCESS CONNECTION – EN/DIN Flanges

A	1	DN 80, PN 16	EN 1092-1 Type B1
A	2	DN 80, PN 25/40	EN 1092-1 Type B1
B	1	DN 100, PN 16	EN 1092-1 Type B1
B	2	DN 100, PN 25/40	EN 1092-1 Type B1
C	1	DN 125, PN 16	EN 1092-1 Type B1
C	2	DN 125, PN 25/40	EN 1092-1 Type B1
D	1	DN 150, PN 16	EN 1092-1 Type B1
D	2	DN 150, PN 25/40	EN 1092-1 Type B1

### DESIGN CODE AND FLANGE MATERIAL

Standard	Design codes			Flange material
	ANSI/ASME B31.3	NACE	ANSI/ASME B31.3 & NACE	
1	2	–	–	Carbon steel
A	E	J	N	Carbon steel w. 316/316L cladding
B	F	K	P	316/316L stainless steel

### SWITCH TYPE (see table on page 2 for full details)

0	SPDT with silver contacts
1	DPDT with silver contacts
2	SPDT with gold plated contacts
3	DPDT with gold plated contacts
4	Hermetically sealed, SPDT with silver contacts
6	Hermetically sealed, SPDT with gold plated contacts

### HOUSING MATERIALS AND CABLE ENTRY

Consult factory for proper partnumbers for FM/CSA approved units

1	Cast aluminium, single 3/4" NPT cable entry,	ATEX II 1/2G EEx d II C T6
2	Cast iron, single 3/4" NPT cable entry,	ATEX II 1/2G EEx d II C T6
3	Cast aluminium, single M20 x 1,5 cable entry,	ATEX II 1/2G EEx d II C T6
4	Cast iron, single M20 x 1,5 cable entry,	ATEX II 1/2G EEx d II C T6
M	Cast aluminium, single 3/4" NPT cable entry,	ATEX II 1G EEx ia II C T6
N	Cast iron, single 3/4" NPT cable entry,	ATEX II 1G EEx ia II C T6
P	Cast aluminium, single M20 x 1,5 cable entry,	ATEX II 1G EEx ia II C T6
R	Cast iron, single M20 x 1,5 cable entry,	ATEX II 1G EEx ia II C T6

T 3 C 0

complete order code for adjustable differential TUFFY®

# T3B: INTERFACE

**DIMENSIONS in mm (inches)**

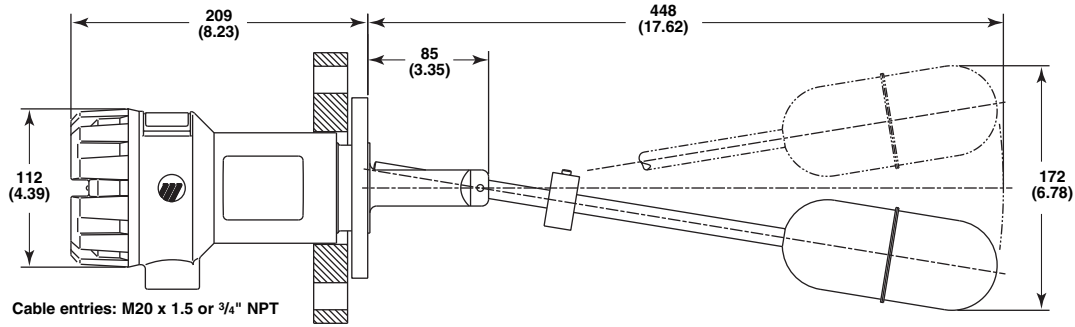

## ORDER CODE

Process connection: up to 300 lbs ANSI / PN 40 flanges  
 Max temperature: switch selection dependant – see table on page 2  
 Max pressure: 50 bar abs. (720 psi)  
 Min S.G. of lower liquid: 0,81 kg/dm<sup>3</sup>  
 Min S.G. difference between both liquids: 0,1 kg/dm<sup>3</sup>  
 Level differential: 44 mm (1.72")

T	3	B	Interface Tuffy with 316/316L (1.4401/1.4404) float - max 50 bar abs. (720 psi)
---	---	---	---

SPECIFIC GRAVITY OF LOWER LIQUID (consult factory for S.G. higher than 1.0 kg/dm<sup>3</sup>)

0,81	0,82	0,83	0,84	0,85	0,86	0,87	0,88	0,89	0,90	Specific Gravity
A	B	C	D	E	F	G	H	J	K	Code
0,91	0,92	0,93	0,94	0,95	0,96	0,97	0,98	0,99	1	Specific Gravity
L	M	N	P	R	S	T	U	V	W	Code

### PROCESS CONNECTION – ANSI Flanges

3	A	3"	150 lbs RF ANSI Flange
3	B	3"	300 lbs RF ANSI Flange
4	A	4"	150 lbs RF ANSI Flange
4	B	4"	300 lbs RF ANSI Flange
5	A	5"	150 lbs RF ANSI Flange
5	B	5"	300 lbs RF ANSI Flange
6	A	6"	150 lbs RF ANSI Flange
6	B	6"	300 lbs RF ANSI Flange

### PROCESS CONNECTION – EN/DIN Flanges

A	1	DN 80, PN 16	EN 1092-1 Type B1
A	2	DN 80, PN 25/40	EN 1092-1 Type B1
B	1	DN 100, PN 16	EN 1092-1 Type B1
B	2	DN 100, PN 25/40	EN 1092-1 Type B1
C	1	DN 125, PN 16	EN 1092-1 Type B1
C	2	DN 125, PN 25/40	EN 1092-1 Type B1
D	1	DN 150, PN 16	EN 1092-1 Type B1
D	2	DN 150, PN 25/40	EN 1092-1 Type B1

### DESIGN CODE AND FLANGE MATERIAL

Design codes				Flange material
Standard	ANSI/ASME B31.3	NACE	ANSI/ASME B31.3 & NACE	
1	2	–	–	Carbon steel
A	E	J	N	Carbon steel w. 316/316L cladding
B	F	K	P	316/316L stainless steel

### SWITCH TYPE (see table on page 2 for full details)

0	SPDT with silver contacts
1	DPDT with silver contacts
2	SPDT with gold plated contacts
3	DPDT with gold plated contacts
4	Hermetically sealed, SPDT with silver contacts
6	Hermetically sealed, SPDT with gold plated contacts

### HOUSING MATERIALS AND CABLE ENTRY

Consult factory for proper partnumbers for FM/CSA approved units

1	Cast aluminium, single 3/4" NPT cable entry,	ATEX II 1/2G EEx d II C T6
2	Cast iron, single 3/4" NPT cable entry,	ATEX II 1/2G EEx d II C T6
3	Cast aluminium, single M20 x 1,5 cable entry,	ATEX II 1/2G EEx d II C T6
4	Cast iron, single M20 x 1,5 cable entry,	ATEX II 1/2G EEx d II C T6
M	Cast aluminium, single 3/4" NPT cable entry,	ATEX II 1G EEx ia II C T6
N	Cast iron, single 3/4" NPT cable entry,	ATEX II 1G EEx ia II C T6
P	Cast aluminium, single M20 x 1,5 cable entry,	ATEX II 1G EEx ia II C T6
R	Cast iron, single M20 x 1,5 cable entry,	ATEX II 1G EEx ia II C T6

T	3	B		0			
---	---	---	--	---	--	--	--

**complete order code for interface TUFFY®**



### 039: PNEUMATIC COMPACT TUFFY (Narrow differential)

DIMENSIONS in mm (inches)

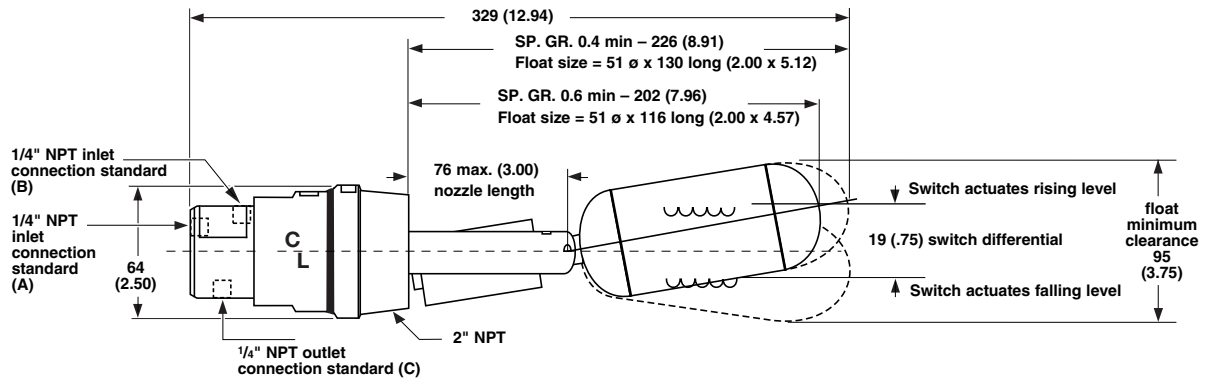

#### ORDER CODE

Process connection: 2" NPT  
 Max temperature: 150 °C (300 °F) @ 103 bar (1500 psi) - S.G: 0,6 and 34 bar (500 psi) - S.G: 0,4  
 Max pressure: 103 bar (S.G: 0,6), 34 bar (S.G: 0,4)  
 Supply pressure: vacuum – 13,8 bar (200 psi)  
 Max leakage rate: 14.16 l/h (0.5 SCFH) @ 6,9 bar (100 psi)  
 Max air flow: 0,34 m³/h (12 SCFH)

0 3 9 - 6 0 0 0 - 1 0	Tuffy level switch, with non-bleed pneumatic switch
-----------------------	---

#### SPECIFIC GRAVITY

0	0.60 min. specific gravity
4	0.40 min. specific gravity

complete order code for pneumatic TUFFY®

### 039: ELECTRIC COMPACT TUFFY (Narrow differential) - for General Purpose only

DIMENSIONS in mm (inches)

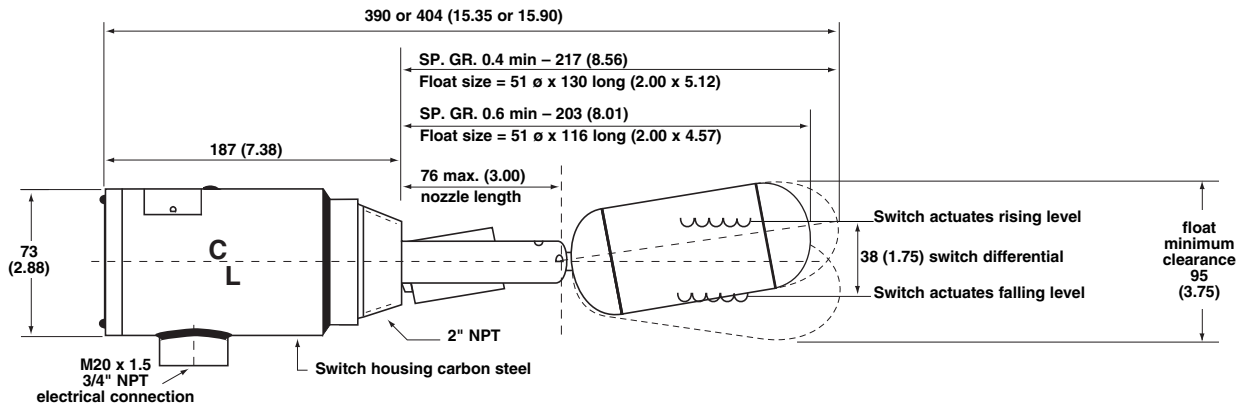

#### ORDER CODE

Process connection: 2" NPT  
 Max temperature: 205 °C (400 °F) @ 103 bar (1500 psi) - S.G: 0,6 or 0,4  
 Max pressure: 103 bar (S.G: 0,6), 34 bar (S.G: 0,4)  
 Electric switch rating: SPDT: 5 A (V AC), 5 A (28 V DC), 0,5 A (125 V DC), 0,25 A (230 V DC)  
 DPDT: 10 A (V AC)

0 3 9 - 5 0 0 0 - 1 0	Tuffy level switch, with SPDT Micro switch - max 5A
0 3 9 - 5 0 0 0 - 6 0	Tuffy level switch, with DPDT Micro switch - max 10A

#### SPECIFIC GRAVITY

0	0.60 min. specific gravity
4	0.40 min. specific gravity

complete order code for electric TUFFY®

# EXTERNAL CAGES FOR NARROW DIFFERENTIAL TUFFY (T31/T32/T33/T35)

DIMENSIONS in mm (inches)

## CAGE – STYLE

Flanged type 035 cage

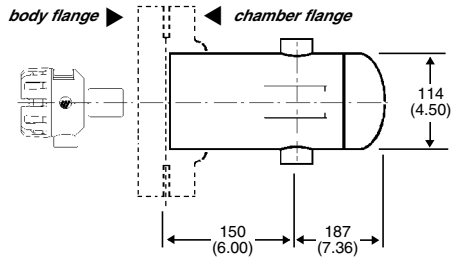

Sealed type 033 cage

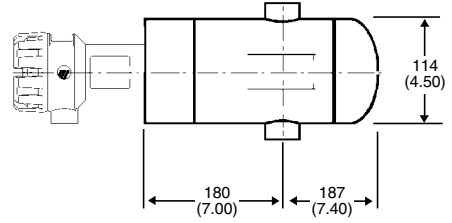

## CAGE – PROCESS CONNECTION

### Threaded/welded

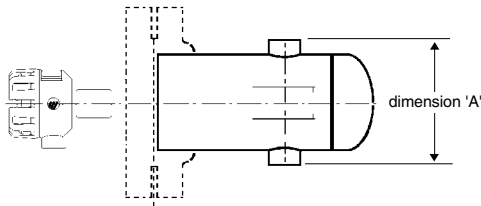

CONNECTION	DIMENSIONS 'A'			
	3/4"	1"	1 1/2"	2"
<i>NPT-F thread</i>	154 (6.06)	164 (6.46)	168 (6.61)	168 (6.61)
<i>Socket weld</i>	154 (6.06)	164 (6.46)	186 (7.32)	202 (7.95)
<i>Butt weld</i>	162 (6.38)	171 (6.73)	184 (7.24)	194 (7.84)

### Flanged

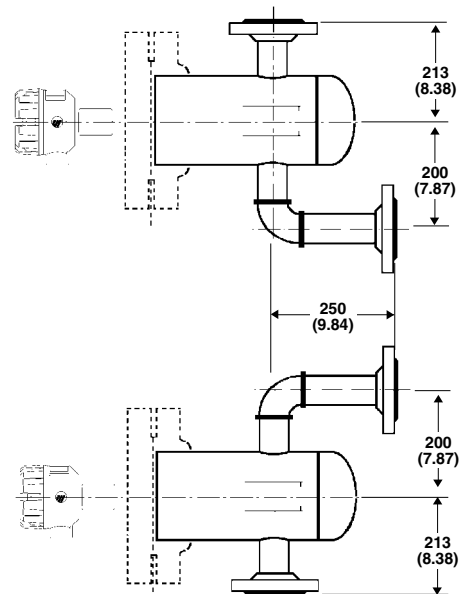
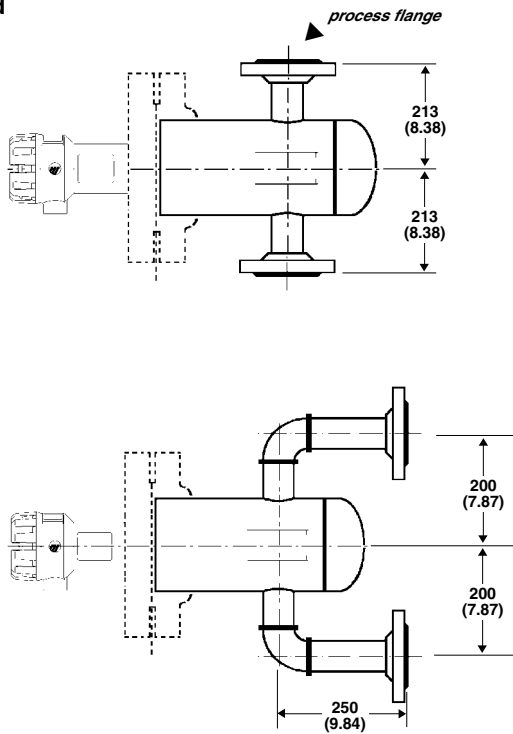

**ORDER CODE**

0 3 3	4" sealed Tuffy cage (2" threaded TUFFY® in cage)
0 3 5	4" flanged Tuffy cage (matches selected flanged TUFFY®)

**MATERIALS OF CONSTRUCTION**

4	Carbon steel body with 316 stainless steel trim
5	316/316L (double certified) stainless steel body with 316 stainless steel trim

**PROCESS CONNECTION – ANSI TYPE RATING**

NPT-F threaded	Socket weld	Butt weld	Slip on flange				Weld neck flange SCH 80			
			RF			RJ	RF			RJ
			150 lb	300 lb	600 lb	600 lb	150 lb	300 lb	600 lb	600 lb
A	B	C	D	E	F	G	L	M	N	P

**PROCESS CONNECTION – EN/DIN TYPE RATING**

Form C (EN1092-1 Type B1)					Form E (EN1092-1 Type B2)	
PN 6	PN 10	PN 16	PN 25	PN 40	PN 63	PN 100
1	2	3	4	5	6	8

**PROCESS CONNECTION – ANSI SIZE**

3/4"	1"	1 1/2"	2"
A	B	C	D

**PROCESS CONNECTION – DIN SIZE**

DN 20	DN 25	DN 40	DN 50
1	2	3	5

**EXTERNAL CAGE CONFIGURATION**

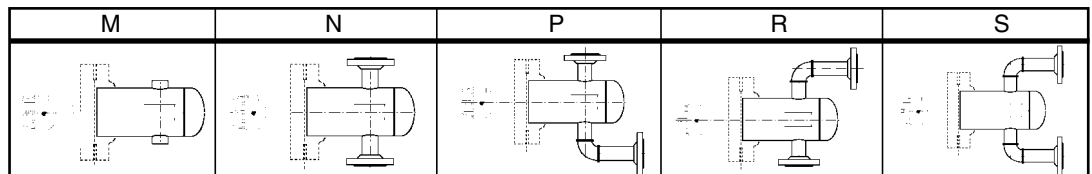

**BODY/CHAMBER FLANGE**

0	For N/P/R/S cage configurations rating is identical to process flange rating
1	For M cage configurations rating: 4" – 150 lb RF flange
2	For M cage configurations rating: 4" – 300 lb RF flange
3	For M cage configurations rating: 4" – 600 lb RF flange

0	3							0	0
---	---	--	--	--	--	--	--	---	---

**complete order code for external cage**

**optional mounting flanges for 2" NPT threaded 039 TUFFY models**

Raised face mounting flanges are available in the sizes and materials shown below. Consult factory (C/F) for additional flange sizes.

ANSI RF Flange		Part number	
Size	Rating	316/316L (1.4401/1.4404)	Carbon steel
3"	150 lbs	004-6820-024	004-6820-001
4"		004-6820-025	004-6820-007
6"		004-6820-026	004-6820-016
3"	300 lbs	004-6820-005	004-6820-002
4"		004-6820-011	004-6820-008
6"		Consult factory	Consult factory
3"	600 lbs	004-6820-006	004-6820-003
4"		004-6820-012	004-6820-009
6"		Consult factory	Consult factory



**QUALITY ASSURANCE - ISO 9001:2000**

THE QUALITY ASSURANCE SYSTEM IN PLACE AT MAGNETROL GUARANTEES THE HIGHEST LEVEL OF QUALITY DURING THE DESIGN, THE CONSTRUCTION AND THE SERVICE OF CONTROLS. OUR QUALITY ASSURANCE SYSTEM IS APPROVED AND CERTIFIED TO **ISO 9001:2000** AND OUR TOTAL COMPANY IS COMMITTED TO PROVIDING FULL CUSTOMER SATISFACTION BOTH IN QUALITY PRODUCTS AND QUALITY SERVICE.

**PRODUCT WARRANTY**

ALL MAGNETROL MECHANICAL LEVEL CONTROLS ARE WARRANTED FREE OF DEFECTS IN MATERIALS AND WORKMANSHIP FOR FIVE FULL YEARS FROM THE DATE OF ORIGINAL FACTORY SHIPMENT. IF RETURNED WITHIN THE WARRANTY PERIOD; AND, UPON FACTORY INSPECTION OF THE CONTROL, THE CAUSE OF THE CLAIM IS DETERMINED TO BE COVERED UNDER THE WARRANTY; THEN, MAGNETROL INTERNATIONAL WILL REPAIR OR REPLACE THE CONTROL AT NO COST TO THE PURCHASER (OR OWNER) OTHER THAN TRANSPORTATION. MAGNETROL SHALL NOT BE LIABLE FOR MISAPPLICATION, LABOR CLAIMS, DIRECT OR CONSEQUENTIAL DAMAGE OR EXPENSE ARISING FROM THE INSTALLATION OR USE OF THE EQUIPMENT. THERE ARE NO OTHER WARRANTIES EXPRESSED OR IMPLIED, EXCEPT, SPECIAL WRITTEN WARRANTIES COVERING SOME MAGNETROL PRODUCTS.



BULLETIN N°: BE 44-118.9  
EFFECTIVE: MAY 2006  
SUPERSEDES: June 2005

**UNDER RESERVE OF MODIFICATIONS**

BENELUX FRANCE	Heikensstraat 6, 9240 Zele, België -Belgique Tél. +32 (0)52.45.11.11 • Fax. +32 (0)52.45.09.93 • E-Mail: info@magnetrol.eu
DEUTSCHLAND	Alte Ziegelei 2-4, D-51491 Overath Tel. +49 (0)2204 / 9536-0 • Fax. +49 (0)2204 / 9536-53 • E-Mail: vertrieb@magnetrol.de
INDIA	C-20 Community Centre, Janakpuri, New Delhi - 110 0058 Tel. +91 (11) 41661840 • Fax +91 (11) 41661843 • E-Mail: info@magnetrolindia.com
ITALIA	Via Arese 12, I-20159 Milano Tel. +39 02 607.22.98 (R.A.) • Fax. +39 02 668.66.52 • E-Mail: mit.gen@magnetrol.it
U.A.E.	DAFZA Office 5EA 722 • PO Box 293671 • Dubai Tel. +971-4-6091735 • Fax +971-4-6091736 • E-Mail: info@magnetrol.ae
UNITED KINGDOM	Unit 1 Regent Business Centre, Jubilee Road Burgess Hill West Sussex RH 15 9TL Tel. +44 (0)1444 871313 • Fax +44 (0)1444 871317 • E-Mail: sales@magnetrol.co.uk

**www.magnetrol.com**

**OUR NEAREST REPRESENTATIVE**